

Plenum Diffuser System

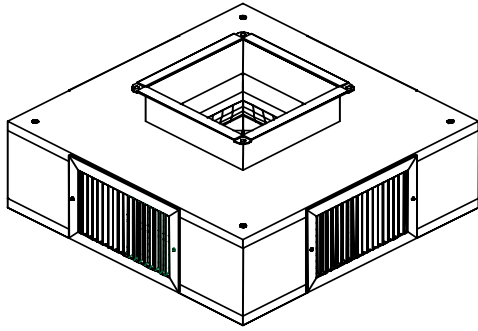

Adaptable Air Products

910 Creekside Road, Chattanooga, TN 37406
 Phone: (423) 698-1003 ~ Fax: (423) 622-4002
 Toll Free: 1-866-227-4462



Model DNAD with Double Deflection Grilles 4-Way Discharge

Features:

- ✓ Double Deflection Grilles for vertical and horizontal air control
- ✓ Two turning vanes in each quadrant
- ✓ Standard TDC duct connection
- ✓ 3/8" threaded insert in each corner for mounting
- ✓ Galvanized steel construction
- ✓ 1", 1-1/2lb internal insulation
- ✓ Curb and duct packages available

PERFORMANCE DATA

| MODEL | Nominal CFM | 0 deg Deflection | | | 22-1/2 deg Deflection | | | 45 deg Deflection | | |
|----------------|-------------|------------------|------|----|-----------------------|------|----|-------------------|------|----|
| | | Throw | P.D. | NC | Throw | P.D. | NC | Throw | P.D. | NC |
| DNAD 1408-5 | 2000 | 41' | .11 | 25 | 33' | .12 | 26 | 21' | .17 | 32 |
| DNAD 1608-6 | 2400 | 44' | .12 | 28 | 36' | .14 | 29 | 23' | .19 | 35 |
| DNAD 2008-7.5 | 3000 | 49' | .13 | 30 | 39' | .15 | 31 | 25' | .22 | 37 |
| DNAD 2010-8.5 | 3400 | 53' | .10 | 27 | 43' | .12 | 28 | 27' | .17 | 34 |
| DNAD 2210-10 | 4000 | 58' | .13 | 33 | 46' | .15 | 34 | 28' | .22 | 40 |
| DNAD 2410-12.5 | 5000 | 63' | .13 | 33 | 50' | .15 | 34 | 31' | .22 | 40 |
| DNAD 2810-15 | 6000 | 69' | .15 | 33 | 55' | .2 | 34 | 35' | .29 | 40 |
| DNAD 3016-20 | 8000 | 84' | .11 | 31 | 67' | .17 | 33 | 42' | .24 | 38 |
| DNAD 3616-25 | 10000 | 90' | .11 | 32 | 72' | .13 | 33 | 45' | .18 | 39 |
| DNAD 3818-30 | 12000 | 98' | .13 | 33 | 78' | .15 | 34 | 49' | .21 | 40 |

Throw based on 50FPM Terminal Velocity

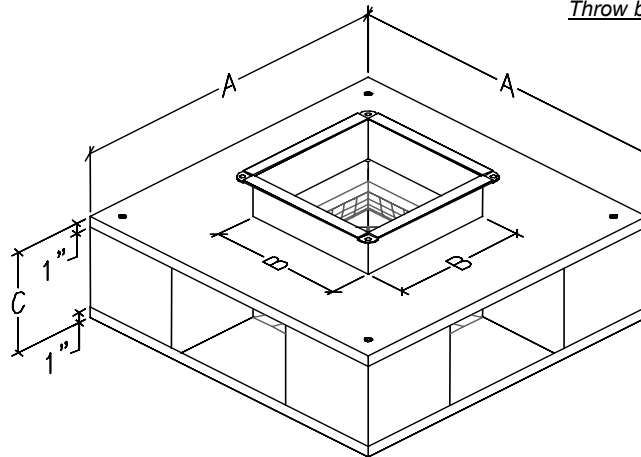

DIMENSIONAL DATA

| MODEL | A | B | C | Grille Size | Weight |
|----------------|-----|-----|-----|-------------|---------|
| DNAD 1408-5 | 34" | 14" | 10" | 14x8" | 44 lbs |
| DNAD 1608-6 | 36" | 16" | 10" | 16x8" | 50 lbs |
| DNAD 2008-7.5 | 40" | 20" | 10" | 20x8" | 61 lbs |
| DNAD 2010-8.5 | 40" | 20" | 12" | 20x10" | 73 lbs |
| DNAD 2210-10 | 42" | 22" | 12" | 22x10" | 81 lbs |
| DNAD 2410-12.5 | 44" | 24" | 12" | 24x10" | 88 lbs |
| DNAD 2810-15 | 48" | 28" | 12" | 28x10" | 105 lbs |
| DNAD 3016-20 | 50" | 30" | 18" | 30x16" | 171 lbs |
| DNAD 3616-25 | 56" | 36" | 18" | 36x16" | 205 lbs |
| DNAD 3818-30 | 58" | 38" | 20" | 38x18" | 215 lbs |

Custom sizes available